

THIS DRAWING IS UNPUBLISHED. RELEASED FOR PUBLICATION FEB ,2004.

© COPYRIGHT 2004 BY TYCO ELECTRONICS CORPORATION. ALL RIGHTS RESERVED.

LOC	DIST	REVISIONS					
E	B	P	LTR	DESCRIPTION	DATE	DWN	APVD
		D		ECR-07-005695	12MAR07	JMS	FWK

NOTES:

- 1 PACK IN ACCORDANCE WITH AMP SPEC 107-3275
- 2 100 TRAY PACK IN ACCORDANCE WITH AMP SPEC 107-3275
- 3 Au PLATING
- 4 Ni PLATING
- 5 ELECTRICAL CHARACTERISTICS  
 FREQUENCY RANGE: 50 Ohm DC - 4 GHz  
 75 Ohm DC - 2 GHz  
 INSULATION RESISTANCE: 5000 MOhm  
 WORKING VOLTAGE: 500 Volts RMS at Sea Level  
 DIELECTRIC WITHSTAND VOLTAGE: 1500 Volts RMS Max  
 CONTACT RESISTANCE:  
 CENTRE CONTACT: 1.50 mOhm Max  
 OUTER CONTACT: 0.20 mOhm Max
- 6 MECHANICAL CHARATERISTICS  
 MOUNT NUT RECOMMENDED TORQUE: 4N  
 DURABILITY: 50 Cycles Min
- 7 ENVIRONMENTAL CHARACTERISTICS  
 OPERATING TEMPERATURE: -65 to +85 DegC
- 8 FOR TECHNICAL DATA REFER TO YOUR LOCAL TYCO ELECTRONICS SALES OFFICE
- 9 ALL DIMENSIONS ARE NOMINAL FOR REFERENCE ONLY UNLESS OTHERWISE STATED

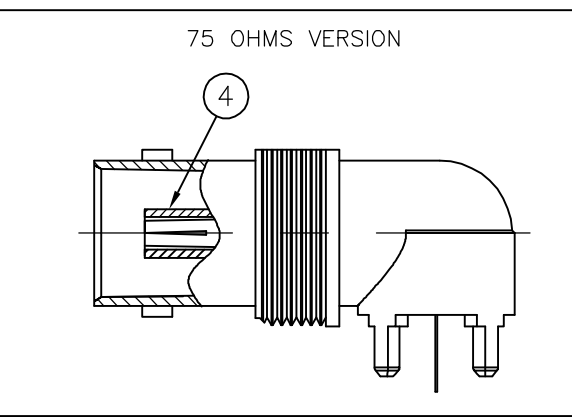
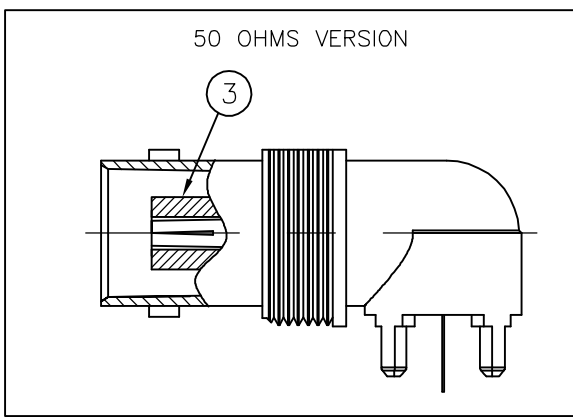
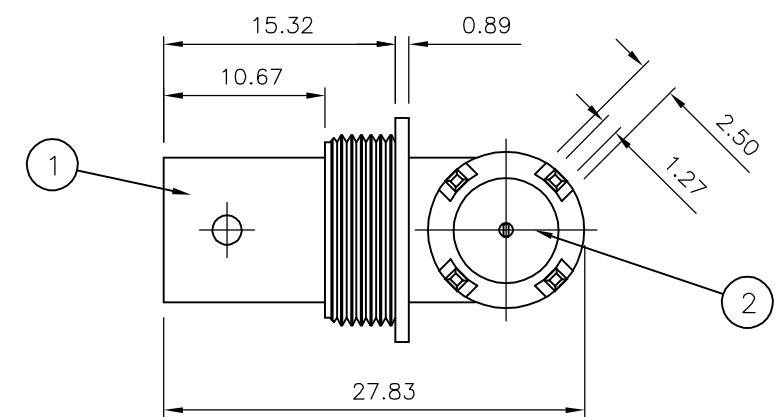
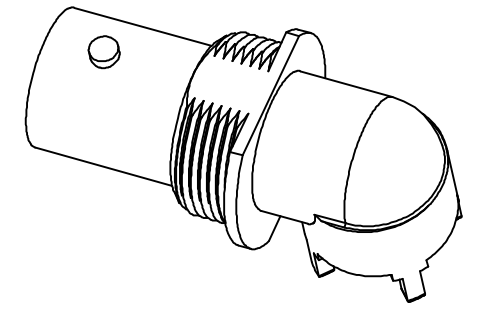
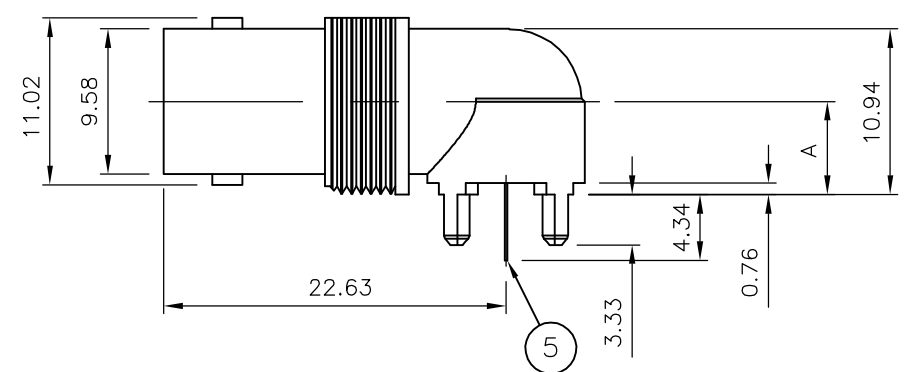
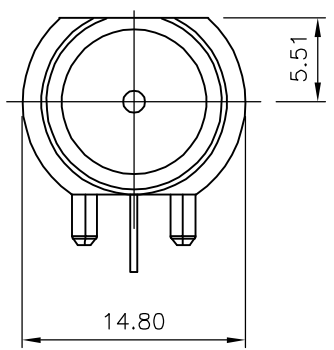

QTY	DESCRIPTION	ITEM
1	PHOSPHER BRONZE	CONTACT 5
1	TPX	INSULATION 4
1	TPX	INSULATION 3
1	PTFE	INSULATION 2
1	ZINC ALLOY	BODY 1
5--7		
5--6		
5--5		
5--4		
5--3		
5--2		
5--1		
5--0		
MATERIAL		DESCRIPTION
QUANTITY PER ASSY		PARTS LIST

QTY	DESCRIPTION	PART NUMBER
6.91	BNC LP ELBOW BULKHEAD PCB SKT 75 OHMS 6.91 BULK	5-1634556-7
6.91	BNC LP ELBOW BULKHEAD PCB SKT 75 OHMS 6.91	5-1634556-6
6.91	BNC LP ELBOW BULKHEAD PCB SKT 50 OHMS 6.91 BULK	5-1634556-5
6.91	BNC LP ELBOW BULKHEAD PCB SKT 50 OHMS 6.91	5-1634556-4
6.15	BNC LP ELBOW BULKHEAD PCB SKT 75 OHMS 6.15 BULK	5-1634556-3
6.15	BNC LP ELBOW BULKHEAD PCB SKT 75 OHMS 6.15	5-1634556-2
6.15	BNC LP ELBOW BULKHEAD PCB SKT 50 OHMS 6.15 BULK	5-1634556-1
6.15	BNC LP ELBOW BULKHEAD PCB SKT 50 OHMS 6.15	5-1634556-0
A	DESCRIPTION	PART NUMBER
DIM		

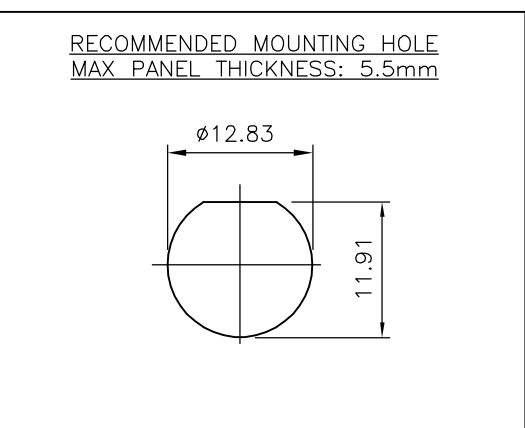
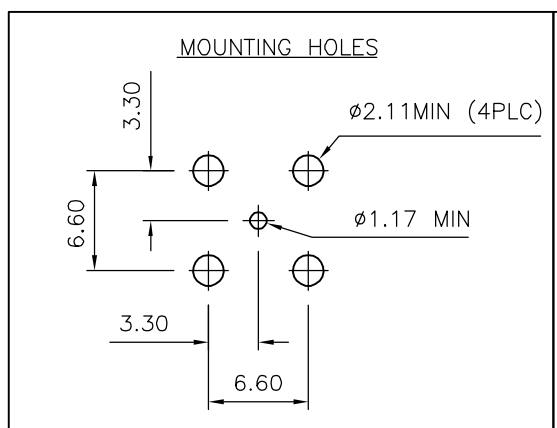

THIS DRAWING IS A CONTROLLED DOCUMENT.		DWN	J.SANDWELL	25FEB04
DIMENSIONS: mm		CHK	S.PARLOW	25FEB04
TOLERANCES UNLESS OTHERWISE SPECIFIED:		APVD	F.WHEELER-KING	25FEB04
0 PLC	± -	NAME		
1 PLC	± -	BNC LP ELBOW BULKHEAD PCB SKT		
2 PLC	± -	50 & 75 OHMS		
3 PLC	± -	PRODUCT SPEC	-	
4 PLC	± -	APPLICATION SPEC	-	
ANGLES	± -	WEIGHT	-	
FINISH	-	CUSTOMER DRAWING	SCALE	NTS

Tyco Electronics Corporation		Bideford, UK, EX39 4HE	
SIZE	A3	CAGE CODE	00779
DRAWING NO	C-1634556		
RESTRICTED TO	-		
SHEET	1	OF	1
REV	D		